

Industrial Articulated Robot

This industrial robot is designed for stacking, unstacking, transferring, stamping, loading, and unloading. It is used in the packing, drinking, chemical, and food industries.



Overview

High-Performance Articulated Robot

This industrial articulated robot is designed for high-efficiency automation tasks including stacking, transferring, and loading/unloading. Featuring 4 degrees of freedom and an AC servo drive system, it provides robust and precise motion control. With a compact footprint and flexible integration capabilities, this unit is an ideal solution for industries such as chemical, food, and packaging.

Key Metrics

Payload Capacity

8 kg

Payload Capacity

1433 mm

Motion Radius

0.08 mm

Repeatability

Technical Specifications

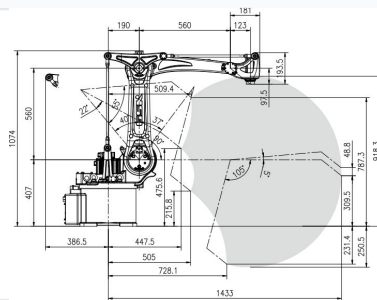

Technical diagram detailing dimensions and workspace envelope for integration planning.

Degrees of Freedom	4
Drive Method	AC Servo Drive
Machine Weight	180 kg
Cycle Time	1800 r/h
Wrist Allowable Load Inertia	0.25 kg·m ²

Applications

Suitable Industries	Packing, Beverage, Chemical, Food
Primary Tasks	Stacking, Unstacking, Transferring, Stamping, Loading, Unloading

Motion Range

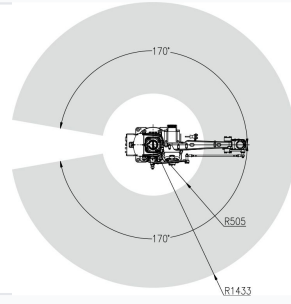

Top-down view of the robot's motion envelope and angular limits.

Joint Motion Range

Joint	Range
J1	±170°
J2	+90° ~ -40°
J3	+68° ~ -90°
J4	±360°

Top Joint Velocities

Joint	Velocity
J1	251
J2	195
J3	195
J4	368